

JUNE 2013



STONESHEET™
SUBSTRATE FOR STONE FACADES
& EXTERIOR TILING



BGC

Fibre Cement

AUSTRALIAN OWNED & MANUFACTURED
WWW.BGC.COM.AU/FIBRECEMENT
WWW.BGCINNOVADESIGN.COM.AU

INNOVA™

BGC'S STUNNING NEW RANGE OF FACADE, LINING AND FLOORING PRODUCTS, INNOVA™ WILL MOVE YOU TO REASSESS YOUR CONCEPT OF EXCELLENCE IN FAÇADES AND FLOORING SYSTEMS. DURABLE AND DYNAMIC, FRESH AND CONTEMPORARY, INNOVA™ IS ALREADY TURNING INDUSTRY HEADS. NOW LET THE INNOVA™ RANGE OF CLADDING AND FLOORING PRODUCTS BREATHE NEW LIFE INTO YOUR CREATIVITY AND PROJECT SPECIFICATION.



STONESHEET™ IS YOUR FIRST CALL FOR A STONE TILE SUBSTRATE AND BACKGROUND FOR TRUE MASONRY ON TIMBER OR STEEL-FRAMED BUILDINGS. A FLAT, SQUARE-EDGED SHEET, STONESHEET™ COMES AS 9MM-THICK PANELS.

DESIGNED SPECIALLY AS A SUBSTRATE FOR BOTH RESIDENTIAL INTERIOR AND EXTERIOR APPLICATIONS, STONESHEET™ IS AN EXCELLENT ALTERNATIVE WHERE OTHER NON-SPECIFICALLY DESIGNED SUBSTRATES HAVE BEEN USED.

STONESHEET™ :

- / EXTERIOR AND INTERIOR STONE TILE FACADES
- / NON STRUCTURAL SUBSTRATE
- / CLASSIFIED TYPE A CATEGORY 3 FOR EXTERIOR USE
- / WILL TAKE MAXIMUM STONE FACADE WEIGHT OF 40KG/M²



CONTENTS

PRODUCT INFORMATION	/ 5
SHEET SIZES & MASS	/ 5
FIRE RESISTANCE	/ 5
QUALITY SYSTEMS	/ 5
HANDLING & STORAGE	/ 5
HEALTH & SAFETY	/ 5
FREEZE THAW	/ 5
SHEET CUTTING & DRILLING	/ 6
FASTENERS	/ 6
SARKING	/ 6
FIXING REQUIREMENTS	/ 7-12
WARRANTY	/ 13
BUSHFIRE & BOUNDARY WALL AREAS	/ 13

APPLICATIONS

Stonesheet™ has been specifically designed for use as a substrate for both interior and exterior stone tile facades. Stonesheet™ is a perfect alternative for use where other non-specifically designed substrates have traditionally been used.

Stonesheet™ is manufactured in standard industry sized sheets and in a thickness of 9mm.

ADVANTAGES

- / Specifically designed to hold stone tile facades
- / Highly durable
- / Can be used for interior and exterior applications

WEIGHT CAPACITY

The installation guidelines in this brochure are detailed to a maximum stone tile weight of 40kg per m². Any stone tile facades above this weight should be certified by a structural engineer or refer to the stone tile facade manufacturer for further details.

ENERGY EFFICIENCY CONSIDERATIONS

Energy efficiency requirements have been introduced into the Building Code of Australia (BCA) for both commercial and residential buildings. Thermal heat transfer into and out of the building envelope will affect the running cost of the building and careful consideration of thermal heat transfer needs to be addressed by the architects, engineers and building designers.

PRODUCT INFORMATION

Stonesheet™ is manufactured from Portland cement, finely ground silica, cellulose fibres and water. It is cured in a high-pressure steam autoclave to create a durable, dimensionally stable product.

Stonesheet™ fibre cement sheets are manufactured to conform to the requirements of AS2908.2 Cellulose-Cement Products and are classified as Type A Category 3 sheet for exterior use.

FIRE RESISTANCE

Stonesheet™ has been tested by the CSIRO – Building, Construction and Engineering Division, in accordance with Australian Standard AS1530.3 – 1989. See report numbers FNE 6966 and FNE 7529.

These reports deemed the following Early Fire Hazard Indices:

- / Ignitability Index 0
- / Spread of Flame Index 0
- / Heat Evolved Index 0
- / Smoke Developed Index 0-1

QUALITY SYSTEMS

BGC Fibre Cement manufactures Stonesheet™ under the rigorous Quality Management System of the International Standard ISO 9002:2000, and is the holder of Licence Agreement number QEC2955/13.

SHEET SIZES & MASS

THICKNESS mm	MASS KG/M ²	WIDTH mm	LENGTH mm
9	13	1200	3000

SHEET TOLERANCES

- / Width +0/-2mm
- / Length +0/-2mm
- / Thickness +10%/-0%
- / Diagonals difference (max) 2mm
- / Edge straightness deviation (max) 1mm

HANDLING & STORAGE

Stonesheet™ must be stacked flat, up off the ground and supported on level bearers at 450mm centres.

The sheets must be kept dry, preferably by being stored inside a building. When stored outdoors they must be protected from the weather.

Care should be taken to avoid damage to the ends, edges and surfaces.

Sheets must be dry prior to being fixed. Sheets must be carried on edge.

HEALTH & SAFETY

Stonesheet™ as manufactured will not release airborne dust, but during drilling, cutting and sanding operations cellulose fibres, silica and calcium silicate dust may be released.

Breathing in fine silica dust is hazardous, prolonged exposure (usually over several years) may cause bronchitis, silicosis or cancer.

AVOID INHALING DUST

When cutting sheets, use the methods recommended in this literature to minimise dust generation.

These precautions are not necessary when stacking, unloading or handling fibre cement products.

For further information or a Material Safety Data Sheet contact any BGC Sales Office or www.bgcinnovadesign.com.au

FREEZE THAW

Stonesheet™ should not be used in situations where it will be in direct contact with snow or ice for prolonged periods.

SHEET CUTTING & DRILLING

Stonesheet™ may be cut to size on site. If using power tools for cutting, drilling or sanding they must be fitted with appropriate dust collection devices or alternatively an approved (P1 or P2) dust mask and safety glasses shall be worn.

It is recommended that work always be carried out in a well-ventilated location.

The most suitable cutting methods are:

/ DURABLADE

180mm Diameter.

This unique cutting blade is ideal for cutting Fibre Cement. Can be fitted to a 185mm circular saw, ie Makita or similar. Please ensure safe working practices when using.



/ DRILLING

Use normal high-speed masonry drill bits. Do not use the drill's hammer function. For small round holes, the use of a hole-saw is recommended.

For small rectangular or circular penetrations, drill a series of small holes around the perimeter of the cut out. Tap out the waste piece from the sheet face while supporting the underside of the opening to avoid damage. Clean rough edges with a rasp.

Large rectangular openings are formed by deeply scoring the perimeter of the opening. Next, form a hole in the centre of the opening (refer method above) then saw cut from the hole to the corners of the opening. Snap out the four triangular segments. Clean rough edges with a rasp. (see method above) Then saw cut from the hole to the corners of the opening. Snap out the four triangular segments. Clean rough edges with a rasp.

FASTENERS

LIGHTWEIGHT STEEL FRAMING

Stonesheet™ is fixed to lightweight steel framing using No.10 Self-Embedding Head Screws. Screws should be driven just flush with the sheet face. Do not overdrive screws.



No.10 x 30mm Countersunk Self Drilling Screw minimum class 3. BGC recommends to pre-drill & countersink the Stonesheet™ prior to fixing.

TIMBER FRAMING

Stonesheet™ is screw fixed to timber frame using a minimum Class 3, 10-12 x 40mm Countersunk Wood Screw suitable for timber.



BGC recommends to pre-drill & countersink the Stonesheet™ prior to fixing.

COASTAL AREAS

The durability of galvanised nails and screws used for exterior cladding in coastal or similar corrosive environments can be as low as 10 years.

For this reason BGC recommends the use of Stainless Steel fasteners within 1km of the coast or other large expanses of salt water.

SARKING

In wall cladding applications, the installation of a Vapour Permeable Sarking between Stonesheet™ and the framing is recommended.

Under windy conditions the building's interior pressure will generally be less than the exterior air pressure, this will tend to draw water through flashing and seals if sarking is not used.

Use of a reflective sarking will enhance the insulation properties of the cladding system.

FIXING REQUIREMENTS

Sheets are to be fixed along all sheet edges over studs on wall cladding applications. Fixing centres must not exceed 200mm for wall cladding.

Do not place fixings closer than 12mm from sheet edges, or closer than 50mm from the sheet corners.

The sheet must be held firmly against the framing when fixing to ensure breakout does not occur on the back.

Coastal Areas – The durability of galvanised screws used for exterior cladding in coastal or similar corrosive environments can be as low as 10 years.

For this reason BGC recommend the use of Stainless Steel fasteners within 1 km of the coast or other large expanses of salt water.

Fasteners are to be flush with sheet surfaces: Over driving fasteners must be avoided.

6mm gap between sheets should be caulked with a 'Neutral Cure' sealant prior to the waterproofing membrane being applied.

FIGURE 1 / SHEET FIXING

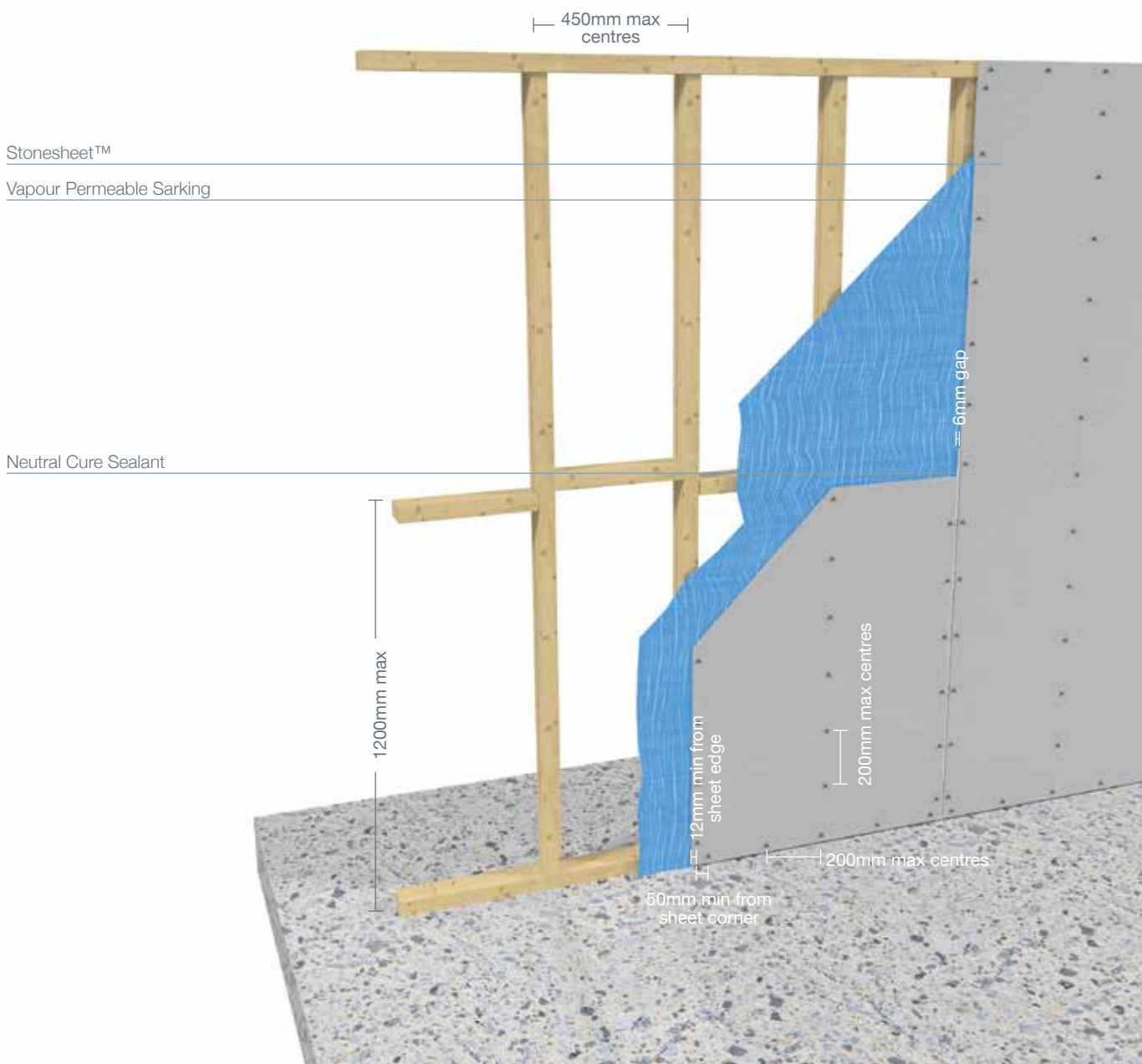

TILE PREPARATION

Stonesheet™ when used as an exterior tile substrate must be fixed to the frame with screws as set out previously in the fasteners section (adhesive or nail fixing of the sheeting is not acceptable for tiled applications.)

BGC recommends the application of a waterproofing membrane to the entire surface of the Stonesheet™ which is compatible with the tiling adhesive.

For fixing of tiles and the installation of the waterproofing membrane, follow the tile manufacturer's instructions.

BGC recommend the use of a flexible tile adhesive complying with Part 1 of Australian Standard AS 2358 – 1990 “Adhesives – For Fixing Ceramic Tiles”. In some tropical regions flexible adhesives may not be suitable – check with the tile merchant or adhesive manufacturer for recommendations.

SUPPORT ANGLES

All tiled areas are to be supported by an appropriate steel angle starting at the bottom. Refer Figure 2 & 3.

The angle is fixed to the bottom section of the wall with Class 3 10g x 50mm Button Head Screws. Max fixing centres 450mm.

The bottom leg of the angle is to support at least one third of the tile thickness.

Support angles are to be installed at heights intervals of 600mm or less where wall heights exceed 3.0m and/ or the tiled weight exceeds 32kg/m². Support angles to be screw fixed through the Stonesheet™ to stud.

FIGURE 2 / SUPPORT ANGLES
0-32kg/m²

3.0-6.0m

0-3.0m

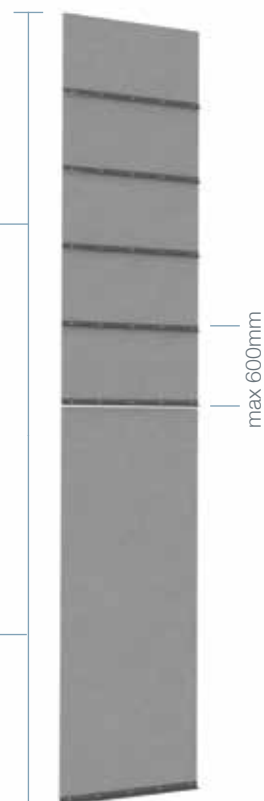

FIGURE 3 / SUPPORT ANGLES
32-40kg/m²

3.0-6.0m

0-3.0m

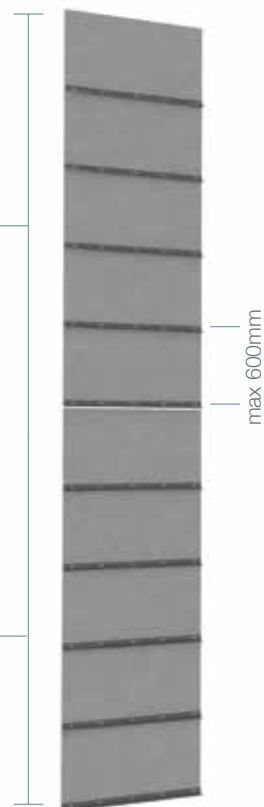

FIGURE 4 / INSTALLATION OF ANGLE BRACKET ON STONESHEET™

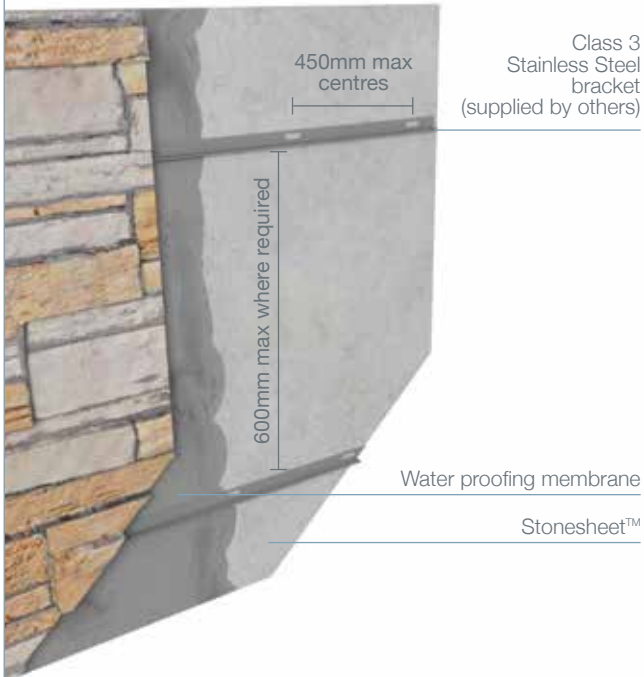

FIGURE 5 / EXAMPLE OF INSTALLATION OF ANGLE BRACKET ON BGC STONESHEET™- SCREW FIXED TO STUD

Cut stone with masonry blade to fit around bracket

To be sealed with Neutral Cure Sealant

1.2mm thick Class 3 Stainless Steel bracket (supplied by others)

Stonesheet™

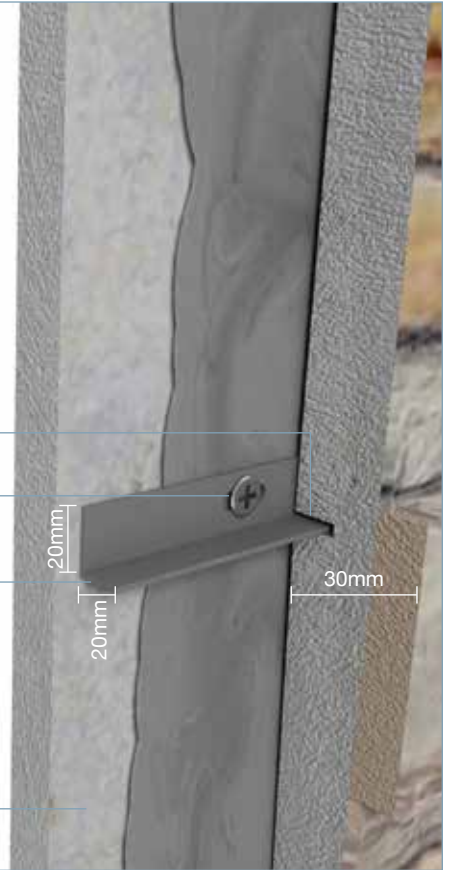

WALL HEIGHTS

Wall heights are to be a maximum of 6.0m. Refer diagrams for maximum wall heights and support angle spacing.

HORIZONTAL RELIEF JOINTS

Horizontal Relief Joints **must** be provided if the wall height exceeds 3000mm or wherever floor joists occur.

FIGURE 6 / HORIZONTAL RELIEF JOINT

Flooring

Vapour Permeable Sarking

Bottom plate (upper floor)

Floor joist

Screw in centre of floor joist

6-8mm gap filled with Neutral Cure Sealant

Class 3 Angled bracket (supplied by others)

Top plate (lower floor)

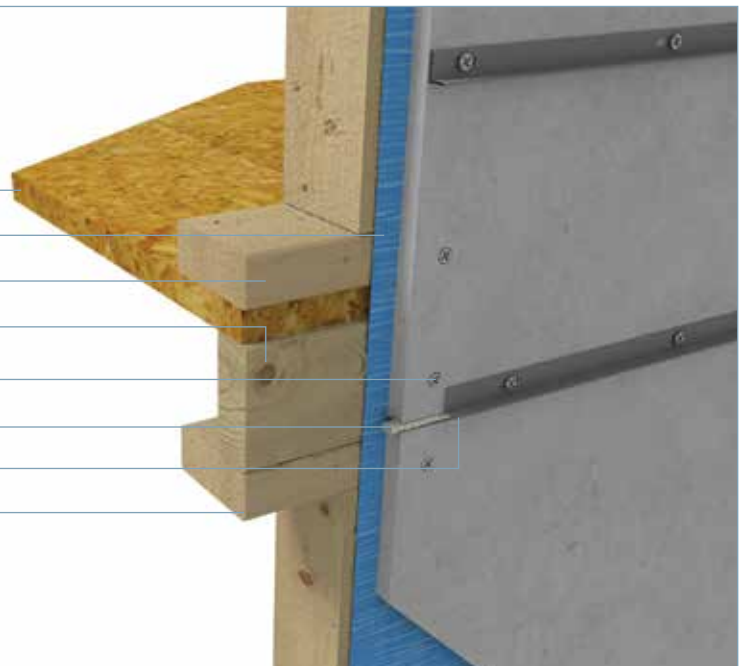

FRAMING

Frame must be designed to be able to carry the additional load of Stonesheet™, stone adhesive and applied stone eccentric total mass not to exceed 56kg/m².

- / Framing must be constructed to comply with the Building Code of Australia.
- / The framing must be set to a true plane to ensure a straight finish to the wall.
- / Studs must be spaced at a maximum of: 450mm centres for Stonesheet™
- / Noggins must be spaced at a maximum of 1200mm centres. For horizontal sheet fixing noggins must support the sheet joints.
- / Maximum frame height 6000mm.

For applications where the added load exceeds 56kgm² or the frame height exceeds 6000mm an engineer should be consulted.

TIMBER FRAMING

Timber framing must comply with AS 1684.2 & .3 - 1999 National Timber Framing Code.

Stonesheet™ must not be fixed to wet framing. It is strongly recommended that kiln dried timber is used for framing.

If sheets are fixed to 'wet' framing problems may occur at a later date due to excessive timber shrinkage.

METAL FRAMING

Metal framing must comply with AS 3623 - 1993 Domestic Metal Framing.

Stonesheet™ may be fixed directly to lightweight metal framing. The metal framing must not exceed 1.6mm in thickness.

DESIGN CONSIDERATION

- / If Stonesheet™ is used with rigid steel framing, it must be battened out with either timber or lightweight steel battens prior to fixing.
- / Timber battens must have a minimum thickness of 40mm to allow adequate fastener penetration. Battens supporting sheet joints must have a minimum actual face width of 45mm.

MOVEMENT CONTROL JOINTS

Movement control joints to be set out as per AS3958.1-2007 section 5.4.5.3. Refer to tile manufacturer for further information.

SHEET LAYOUT FOR CLADDING

Information in this publication is satisfactory for low-rise (up to two story) domestic and light commercial buildings in non-cyclonic regions.

Stonesheet™ cladding should be fixed vertically.

Framing must support all sheet joints.

Stonesheet™ is to be fixed along all sheet edges ie. Top & Bottom plates and studs at 200mm maximum fixings centres.

Do not place fixings closer than 12mm from sheet edges, or closer than 50mm from sheet corner.

WALL ABUTMENT

Control Joints must be employed when an addition is constructed onto an existing building or when a masonry wall adjoins a timber or steel framed construction.

Control Joints should be constructed using 9mm diameter backing rod and polyurethane sealant on abutment to existing masonry walls. See figure 7.

FIGURE 7

6mm Control Joint Structural break with top & bottom plates

Damp Course

Packing

Timber Frame

Vapour Permeable Sarking

Stonesheet™

Cut Stone Tile

Masonry Wall

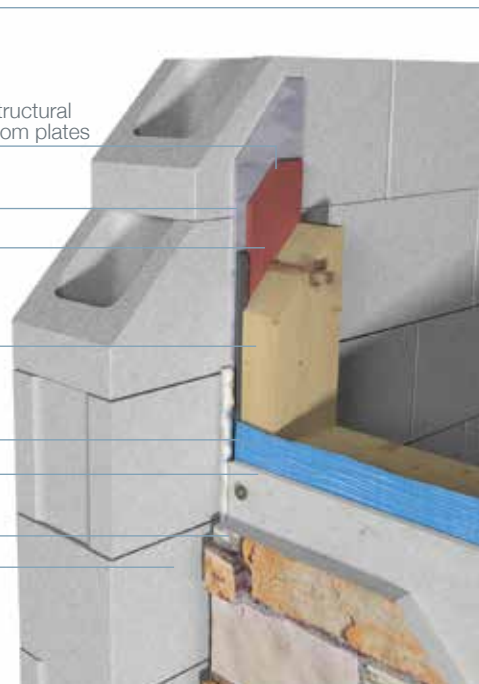

Note: BGC recommend to apply a waterproofing membrane such as Ardex WPM002 to the entire surface of the Stonesheet™ prior to tiling. Tiling adhesive to be compatible with the membrane.

SHEET JOINTS

FIGURE 8 / SHEET JOINT LIGHT WEIGHT STEEL FRAMING

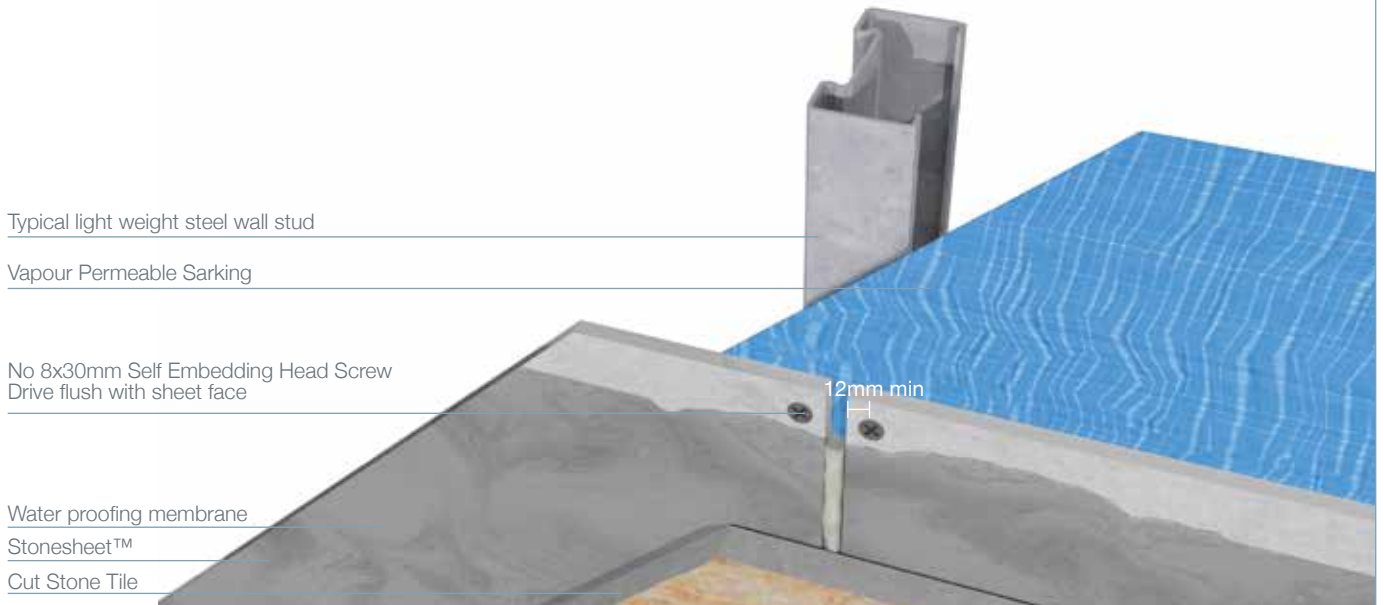
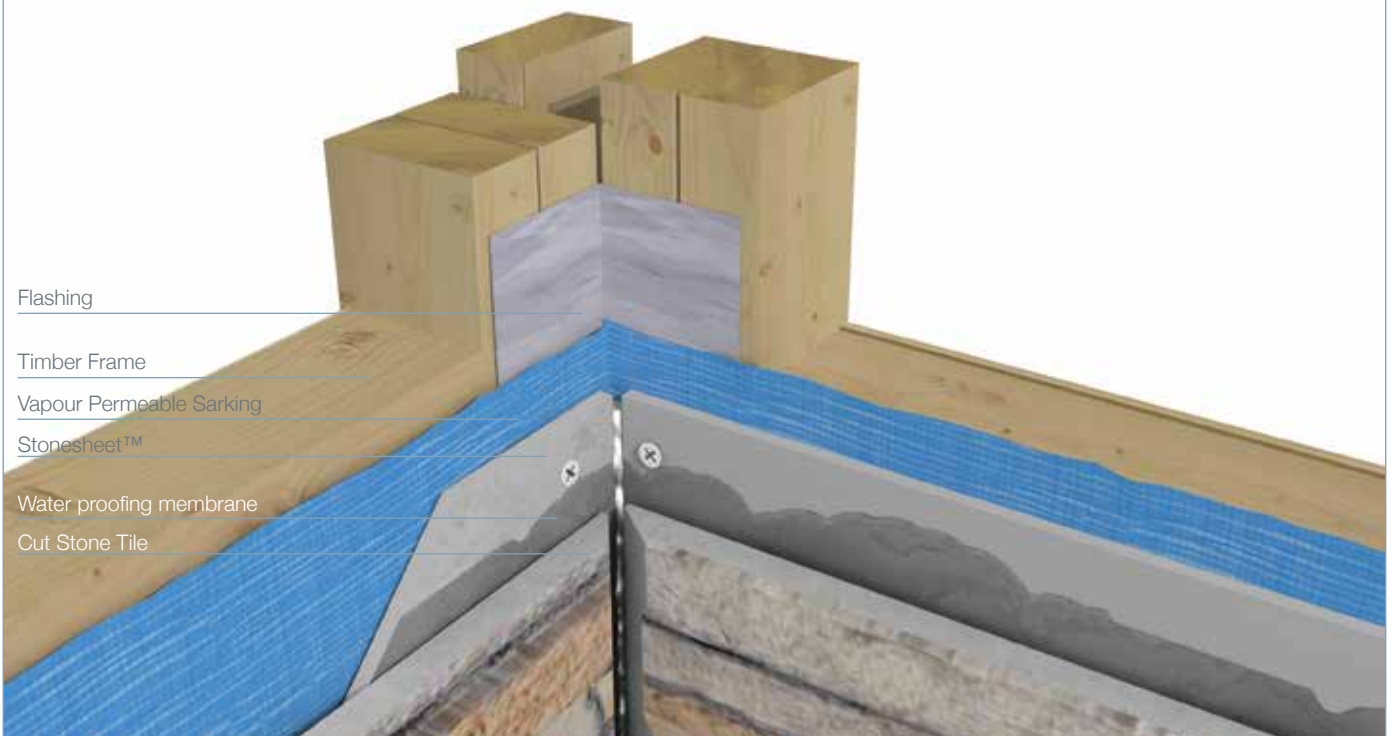

FIGURE 9 / Interior CORNERS



SHEET JOINTS

FIGURE 10 / Exterior CORNERS

Timber Frame

Vapour Permeable Sarking

Stonesheet™

Cut Stone Tile

Flashing

Water proofing membrane

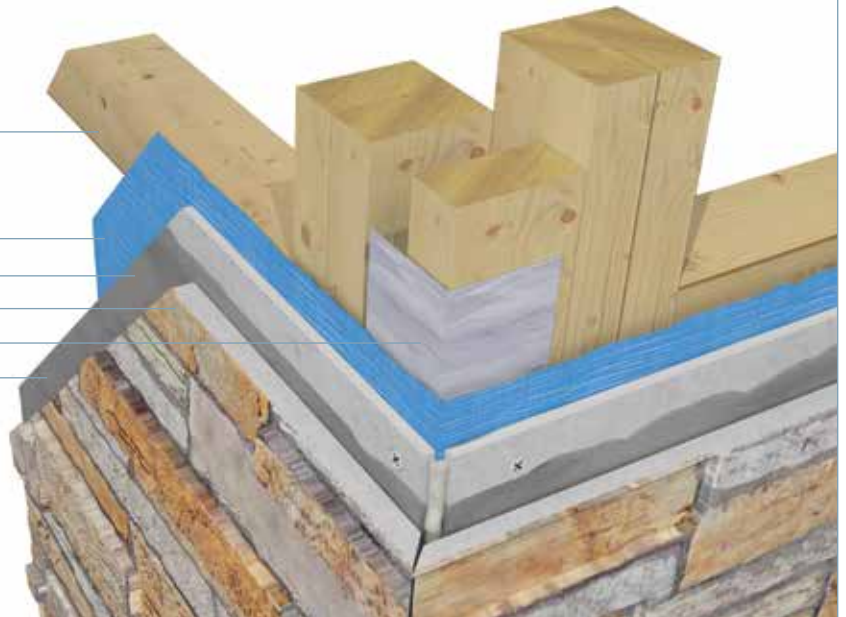

GROUND CLEARANCE

Stonesheet™ must not be used in situations where it will be below ground or where it will be buried in the ground.

A minimum of 100mm must be maintained from the bottom edge of the sheet to the ground, see Figure 11.

FIGURE 11 / GROUND CLEARANCE

Timber Frame

Vapour Permeable Sarking

Water proofing membrane

Support angle

Cut Stone Tile

Stonesheet™

Dampcourse

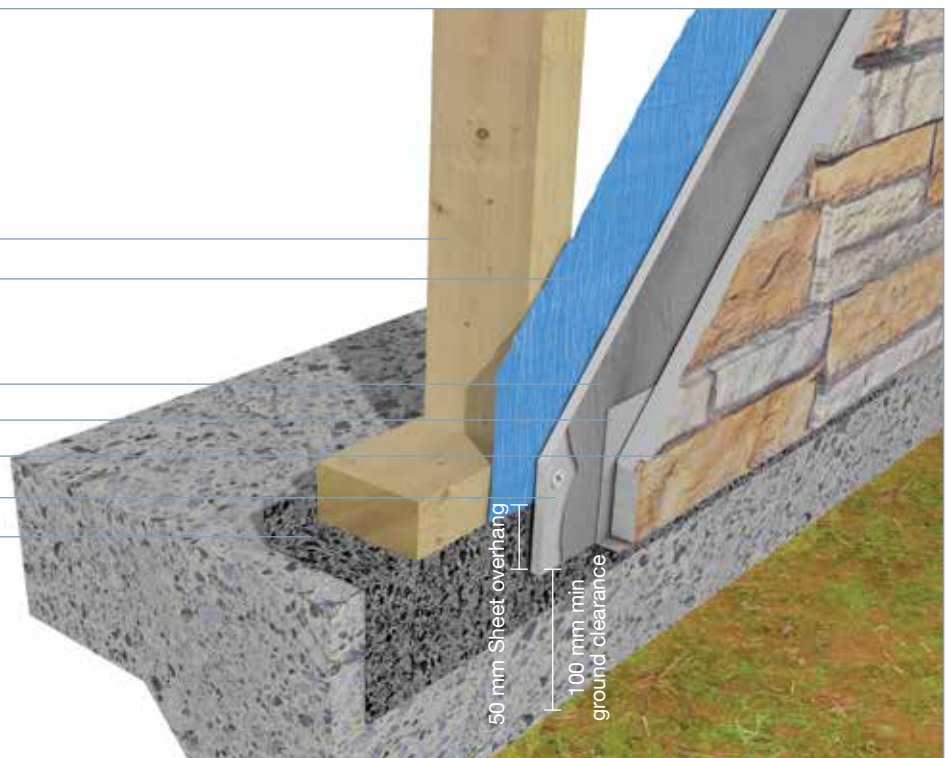

BRACING

Please contact your state BGC Fibre Cement office for advice.

We warrant that our products are free from defects caused by faulty manufacture or materials for a period of 15 years from the date of purchase. If you acquire any defective products, we will repair or replace them, supply equivalent replacement products or refund the purchase price within 30 days of receiving a valid claim subject to product inspection and confirmation of the existence of a defect by BGC. We will bear the cost of any such repair, replacement or refund.

This warranty is given by:

BGC Fibre Cement Pty Ltd
121 Bannister Rd Canningvale WA 6155
Phone 08 9334 4900 Fax 08 9334 4749

To claim under this warranty, you must provide proof of purchase as a consumer and make a written claim (including any costs of claiming) to us at the address specified above within 30 days after the defect was reasonably apparent, or if the defect was reasonably apparent prior to installation, the claim must be made prior to installation. You may not claim under this warranty for loss or damage caused by:

- faulty or incorrect installation by non-BGC installers (BGC's installation procedures are at bgc.com.au/FibreCement);
- failure to comply with the Building Code of Australia or any applicable legislation, regulations approvals and standards;
- products not made or supplied by BGC;
- abnormal use of the product; or
- normal wear and tear.

The benefits available under this warranty are in addition to other rights and remedies of the consumer under the law. Our goods come with guarantees that cannot be excluded under the Australian Consumer Law. You are entitled to a replacement or refund for a major failure and for compensation for any other reasonably foreseeable loss or damage. You are also entitled to have the goods repaired or replaced if the goods fail to be of acceptable quality and the failure does not amount to a major failure.

Stonesheet™ is eminently suited for bushfire wall applications in residential and multi residential buildings. Stonesheet™ when used as a lining product for exterior tiling will achieve up to and including BAL-40 when fixed to frame as per the fixing instructions in this manual.

NOTE: All exterior walls must have sarking beneath the Stonesheet™. No adhesives are to be used when installing the Stonesheet™. Screws must be used.

For more information please contact your nearest BGC Fibre Cement office.

BOUNDARY/EXTERIOR WALLS

AS3959:2009 sets out a series of Bushfire threat levels to buildings described as BAL (Bushfire Attack Levels) as follows: BAL-Low, BAL-12.5, BAL-19, BAL-29, BAL-40 or BAL-FZ (Flamezone).

Stonesheet™ may be used to achieve up to and including BAL-40 as per the requirements of AS3959:2009 Construction of buildings in bushfire-prone areas.

A large area of the page is filled with horizontal dashed lines, providing a template for handwritten notes.

Area with horizontal dashed lines for notes.

CONTACT

TO CONTACT
YOUR NEAREST
BGC STOCKIST,
PLEASE CALL:

ADELAIDE
TELEPHONE
08 8250 4962

BRISBANE
TELEPHONE
07 3271 1711

MELBOURNE
TELEPHONE
03 9392 9444

PERTH
TELEPHONE
08 9334 4900

SYDNEY
TELEPHONE
02 9771 9660

NEW ZEALAND
TELEPHONE
0011 64 9264 1457

TECHNICAL HELP LINE
1300 652 242

BGC Fibre Cement



Quality
ISO 9001
SAI GLOBAL

**BGC FIBRE CEMENT IS A
PROUD AUSTRALIAN OWNED
MANUFACTURER OF FIBRE
CEMENT PRODUCTS.**

**BGC FIBRE CEMENT PROVIDES
BUILDERS, DEVELOPERS AND
ARCHITECTS WITH A RANGE OF
DESIGN ALTERNATIVES AND
INNOVATIVE PRODUCTS,
SUCH AS:**

EXTERIOR PRODUCTS AND APPLICATIONS INNOVA RANGE OF PRODUCTS

DURACOM™ / A compressed fibre cement facade system.

DURAFLOOR™ / Is the ultimate flooring product that can
used in both interior and exterior applications.

DURAGRID™ RESIDENTIAL & DURAGRID™ LIGHT COMMERCIAL /
A light weight facade giving a modern and durable finish.

DURAGROOVE™ / A vertically grooved exterior facade panel.

DURASCAPE™ / A lightweight exterior facade base sheet with
a subtle vertical shadow line.

NULINE™ PLUS / A weatherboard style cladding system.

STONESHEET™ / Purpose designed substrate for stone tile facade.

STRATUM™ / Is a trio of plank products, each of which can be used
as stand alone products or used together to create a striking exterior
cladding solution.

EXTERIOR PRODUCTS AND APPLICATIONS BGC FIBRE CEMENT RANGE OF PRODUCTS

DURASHEET™ / Ideal for the cladding of gables and lining of
eaves. Can also be used on commercial soffits and cladding
on non impact areas.

DURAPLANK™ / Available in Smooth, Woodgrain and Rusticated
finishes, Duraplank™ is ideal for exterior cladding of upper storey
conversions or ground level extensions.

DURATEX™ / A base sheet used for textured coatings on exterior
wall applications.

DURALATTICE™ / Square or diamond patterned lattice, suitable for
screens, pergolas and fences.

COMPRESSED / Used for domestic, commercial sheet for wet areas,
flooring, partitions, exterior decking, fascia and facade cladding.

DURALUX™ / Suitable for exterior applications where it will be
sheltered from direct weather.

INTERIOR PRODUCTS AND APPLICATIONS BGC FIBRE CEMENT RANGE OF PRODUCTS

DURALUX™ / An interior lining board suitable for ceilings and soffits.

DURALINER™ / An interior lining board, this is the perfect
substrate for tiles and is ideal for wet areas.

CERAMIC TILE UNDERLAY / A substrate for ceramic
and slate floor tiles.

VINYL CORK FLOOR COVERINGS /
A substrate for vinyl floors.