



The World's #1 Decking Brand

# INSTALLATION

*Before installing any Trex® product, you should review local building codes and regulations, and consult with local building officials, to ensure compliance and safety.*

## GLOSSARY OF TERMS

<b>Carriage Bolt</b>	A bolt with a rounded head and a square shoulder under the head to prevent turning during installation.
<b>Connector Clip</b>	Hidden fastener used between deck boards to secure positioning.
<b>Joist</b>	A horizontal structural pressure-treated board that runs from wall-to-wall, wall-to-beam, or beam-to-beam to support the deck floor and decking materials.
<b>Lag Bolt</b>	A large metal fastener with a hex head and screw threads that drive it into the wood.
<b>Ledger Board</b>	A beam supporting one end of the joists.
<b>Nosing</b>	The rounded front edge of a stair tread.
<b>Pan-head Screw</b>	Self-tapping screw with W-cut design and slightly rounded head.
<b>Rim Joist</b>	A joist on either side or the end of the deck. May have stairs attached and typically opposite of the ledger board.
<b>Riser</b>	The vertical board nailed to a stringer.
<b>Scarf Cut</b>	A joint used to join two pieces of decking end-to-end, usually cut at a 45° angle.
<b>Self-tapping Screw</b>	A fastener that taps and drills its own hole and does not require a pre-drilled hole.
<b>Stair Tread</b>	Steps or stairway boards that are the steps.
<b>Start Clip</b>	Metal clips used at the end of decking boards to secure them in position.
<b>Stringer</b>	The structural member in a stairway that supports the treads and risers.
<b>Universal Fastener</b>	Plastic 6 mm self-gapping hidden fastener that has increased durability and allows for easier and faster installation than traditional fasteners.

## GENERAL TIPS

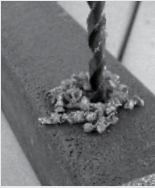
- » Most coloured chalk lines are permanent. **Use baby powder.**
- » We **DO NOT** recommend sanding. Sanding will change the appearance of the surface of Trex material and **will void the warranty with respect to any condition caused by such sanding.**
- » When drilling large or deep holes, periodically lift the bit out of the hole to remove the shavings. 
- » If you want to minimize the appearance of joists through the spaces between boards, paint the top of your joists black.
- » Trex® decking is suitable for a wide range of applications. It is not intended for primary structural members such as load bearing columns, joists, stringers and beams.
- » All boards are over length and all factory ends must be trimmed at installation.
- » Construction methods are always improving. Please make sure you have the most up-to-date installation instructions by visiting [trex.com](http://trex.com).



**ALWAYS GREEN: Trex decking is made of 95% recycled materials,** including plastic packages, reclaimed wood and sawdust.

## SAFETY

When working on any construction project, you should wear protective clothing and safety equipment. Wear safety glasses, gloves, a dust mask and long sleeves, particularly when cutting in confined spaces.

Trex decking and railing are heavier and more flexible than wood. **DO NOT** try to lift the same quantity of Trex boards as you would traditional lumber. Go to [Trex.com](http://Trex.com) for Material Safety Data Sheets (MSDS).

## TOOLS

You can create intricate shapes, profiles, and patterns with Trex. Most installments require no special tools. For best results, use carbide-tipped blades and router bits.

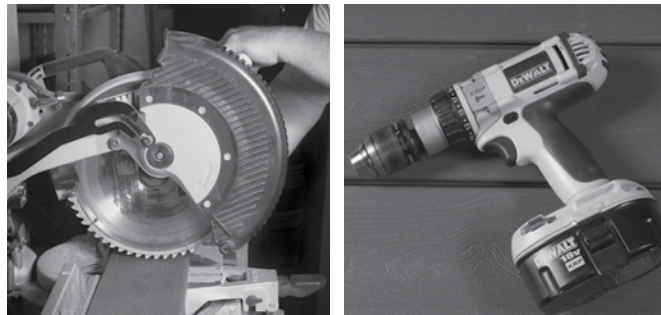

When using a miter saw, we recommend a 254 mm - 305 mm saw blade with 40 teeth or less.

Install Trex recommended fasteners with standard power drills.

## DECKING FASTENERS

For best results, we recommend Trex Hideaway® Hidden Fasteners, which work well and provide an attractive appearance.

If any condition occurs which is attributable to the use of non-recommended fasteners, such condition shall not be covered under Trex's Limited Warranty.



**Start Clip**



**Universal Fastener**

## HIDDEN FASTENER TIPS

### Start Clips Needed

You will need 2.5 clips per lineal meter of start board and finish board.

CONNECTOR CLIPS NEEDED					
Joist Spacing (on center)	Deck dimension in square meters				
	10	20	30	40	50
305 mm	230	460	640	920	1150
450 mm	180	360	540	720	900

### Calculating the Number of Connector Clips Needed

- » # of joists x # of decking boards = # of connector clips needed.
- » Ninety connector clips will cover approximately 5 m<sup>2</sup> using 140 mm decking boards on 450 mm centers.

**NOTE:** When using hidden fasteners (both start and connector clips), one must be used on every joist.

# AUSTRALIAN PHYSICAL & MECHANICAL PROPERTIES OF TREX TRANSCEND® AND TREX ENHANCE®

CRITERION	TEST METHOD	RESULTS	TEST EXPLANATION
<b>Friction Coefficient</b>	<b>AS / NZS 4586 : 2004</b>	<b>Result/Class</b>	
Transcend & Enhance	Appendix A, Wet Pendulum	28/ Y (high) [Transcend] 30/ Y [Enhance]	Contribution to slip when wet with water
Transcend & Enhance	Appendix B, Dry	0.45/ F-Pass [Transcend] 0.45/ F [Enhance]	Classification of Pedestrian Surface Materials according to dry floor friction test
Transcend & Enhance	Appendix A, B (dual)	Y	
Transcend & Enhance	Appendix C, wet barefoot ramp	31 degrees/ C (highest class)	Classification of Pedestrian Surface Materials based on wet barefoot ramp test. Class A = lowest angle; C = highest angle. (higher is better)
Transcend & Enhance	Appendix D, oil-wet ramp	15.1 degrees / R10 [Transcend] 17.4 degrees / R10 [Enhance] (both Class 3 of 6)	Classification of Pedestrian Surface Materials according to dry floor friction test
<b>Combustion Testing</b>	<b>AS 1530.8.1-2007</b>		
Trex Transcend - Square Profile Trex Transcend - Groove Profile		BAL A29 [Square] BAL A19 [Groove]	A burning 'crib' is placed on a constructed Trex deck. The peak 'heat flux' is evaluated at its maximum and recorded

\* Australian Lab = Exova Warringtonfire – Melbourne, Vic., Australia

<b>Combustion Testing</b>	<b>AS 3837:1998</b>		
Transcend & Enhance	Avg heat release	144.7 kW / m <sup>2</sup> 140.6 kW / m <sup>2</sup>	Measured 600 seconds after ignition
Transcend & Enhance	Max heat release rate	437.2 kW / m <sup>2</sup> 365.3 kW / m <sup>2</sup>	Maximum heat released at any point in 60 minute test

\* Australian Lab = CSIRO Materials Science and Engineering – North Ryde, NSW, Australia

# PHYSICAL & MECHANICAL PROPERTIES OF TREX TRANSCEND AND TREX ENHANCE

CRITERION	TEST METHOD	RESULTS	TEST EXPLANATION
<b>Thermal Expansion Coefficient</b> (Transcend and Enhance)	<b>ASTM D696</b>		
Width		8.94 x 10 <sup>-5</sup> cm/cm/C	Distance a 305 mm sample expands or contracts in the width direction at various temperatures
Length		4.1 x 10 <sup>-5</sup> cm/cm/C	Distance a 305 mm sample expands or contracts in the length direction at various temperatures
<b>Compressive Strength</b> (Transcend and Enhance)	<b>ASTM D695</b>		
Surface		12.45 MPa	Force required to compress the surface of a sample between two (2) 50 mm spheres for a 0.2 mm indentation
Edge		13.40 MPa	Force required to compress the surface of a sample between two (2) 50 mm spheres for a 0.2 mm indentation
<b>Relative Density [g/cm<sup>3</sup>]</b> (Transcend and Enhance)	<b>ASTM D792</b>		
		1.05	Mass per unit volume as compared to water (1.00 g/cm <sup>3</sup> )
<b>Resistance to Fungal Infestation</b>	<b>ASTM D1413</b>		
[Brown, White Rot]		No decay	Samples are subjected to wood destroying fungi (white and brown rot) and evaluated for decay and weight loss.
<b>Screw Retention</b> (Transcend and Enhance)	<b>ASTM D1761</b>		
#8 screws		1,377.25 N/m	Amount of force it takes for a screw to be removed from a deck board
<b>Water Absorption</b> (Transcend and Enhance)	<b>ASTM D1037</b>		
Vol. %		<0.5%	Weight gain measurement of a deck board when immersed in water for 24 hrs.
Mass %		0	Change in mass measurement of a deck board when immersed in water for 24 hrs.

\* ASTM (American Society for Testing of Materials) tests conducted at Washington State University (Pullman, WA, USA)



# TREX TRANSCEND®, TREX ENHANCE® AND TREX SELECT® CARE AND CLEANING GUIDE

All exterior building materials require cleaning. Generally, soap and water is all that is required to clean Trex Transcend, Enhance and Select products. For further information, see below.

PROBLEM	SOLUTION
Dirt and Debris	The affected area should be sprayed off with a hose to remove surface debris. Use warm soapy water and a soft bristle brush to remove dirt and debris from the embossing pattern.
Hard Water Staining	Hard water is water with a high amount of mineral deposits like lime, silica and calcium. When the water dries, deposits are left behind, leaving unsightly spots on surfaces. This is not a defect of Trex products but an issue with the water itself. Generally these deposits can be cleaned with white vinegar on decking surfaces or use of Magic Eraser® on railing surfaces. Rinsing is required so care should be taken to not use hard water for this purpose, and if it must be used, dry with a cloth or use a blower to dry surfaces.
Chalk Lines	Most colored chalks are permanent and may discolor the surface. Use only Irwin Strait-Line®* Dust-Off Marking Chalk (purple), available at <a href="http://Irwin.com">Irwin.com</a>
Tannins Due to Debris	Remove all debris from the deck using a hose or broom. Once the deck surface is dry, apply a deck "brightener"*** to the deck as directed by the manufacturer. Deck Brighteners contain oxalic acid, which will also remove tannins.
Ice and Snow	A plastic shovel may be used to remove snow from the deck. Use calcium chloride or rock salt to melt the snow and ice from the deck surface.
Oil, Grease and Food	All food spills should be removed as soon as possible. <b>The surface must be cleaned within seven days to maintain the stain warranty.</b> To remove, spray off with a hose and use warm, soapy water and a soft bristle brush to remove spills from the embossing pattern.
Mold and Mildew	If debris such as pollen and dirt is allowed to remain on the deck surface, mold can feed on the biofilm. Using a hose and warm, soapy water with a soft bristle brush is recommended to remove the food source and mold.
Using a Pressure Washer (Concrete, Stucco or Ground-in Construction Dirt)	A pressure washer with <b>no greater</b> than 3100 psi*** that has a fan attachment/adjustment and soap dispenser may be used to remove dirt, concrete dust, or other types of construction dirt. Spray deck with soap, then follow with gently scrubbing each deck board with a soft bristle brush. Spray/rinse each individual deck board using a fan tip no closer than 8-in from the decking surface. <b>RINSE THOROUGHLY.</b> If dirty water from cleaning is left to dry, this will cause a film to remain on the decking surface.
Maintaining Transcend and Select Railing	<b>NEVER</b> use acetone or other solvents on Trex Transcend or Select railing to maintain the beauty of the surface. For color transfer issues (from attachment of baluster spacer), use Mr. Clean® Magic Eraser® Original or Magic Eraser® Extra Power to help remove this. **** For small surface scratches, marks or scuffs, use Dupli-Color Scratch Seal™ Clear Sealer Pen.*****
Job Site Storage	Store decking on a flat level surface, and always use proper supports (dunnage). Do not store directly on the ground. When stacking decking bundles, supports (dunnage) should start approximately 8-in (0.20 m) from each end and be spaced approximately 2-ft (0.61 m) on center. In addition, supports (dunnage) should line up vertically/perpendicular to the decking product. Adjust support blocks (dunnage) accordingly if bundles are loose. For Select decking, 1x12 and 1x8 products, the maximum stack height is 12 bundles. For all other decking products maximum stack height is 14 bundles (IMPORTANT TO NOTE THAT PROPER DUNNAGE SPACING MUST BE IN PLACE FOR THESE HEIGHTS.) When stacking multiple bundles, ensure that dunnage lines up vertically down through each stack. Always cover decking products on site until ready to be installed.

\*Strait-Line® is a registered trademark of Irwin Industrial Tool Company.

\*\*Use of products containing bleach or acid will lighten the surface of Trex. Use in an inconspicuous area to determine whether you like the effect. Neither product will affect the structural integrity of Trex.

\*\*\*Use of a pressure washer greater than 3100 psi could damage the boards and void the warranty.

\*\*\*\*Mr. Clean® and Magic Eraser® are registered trademarks of The Procter and Gamble Company.

\*\*\*\*\*Scratch Seal™ Clear Sealer Pen is a registered trademark of Dupli-Color® Products Company.

## SPECIAL PATTERNS

When planning a unique pattern, you will need to adjust the framing to support the surface pattern. Many decks are designed to take advantage of angles, as shown below.

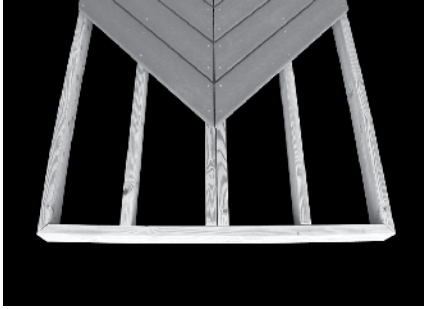

Herringbone Pattern

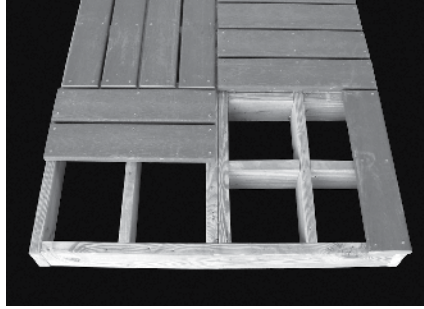

Tile Pattern

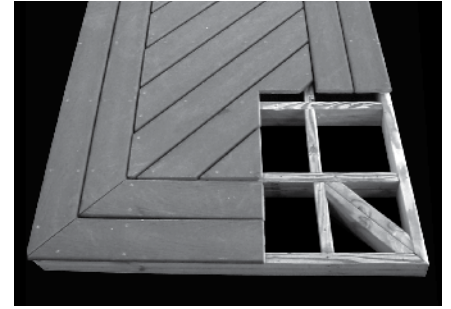

Picture Frame Pattern

---

## ROOFTOP AND SLEEPER DECK SYSTEMS

### Sleeper Deck Systems

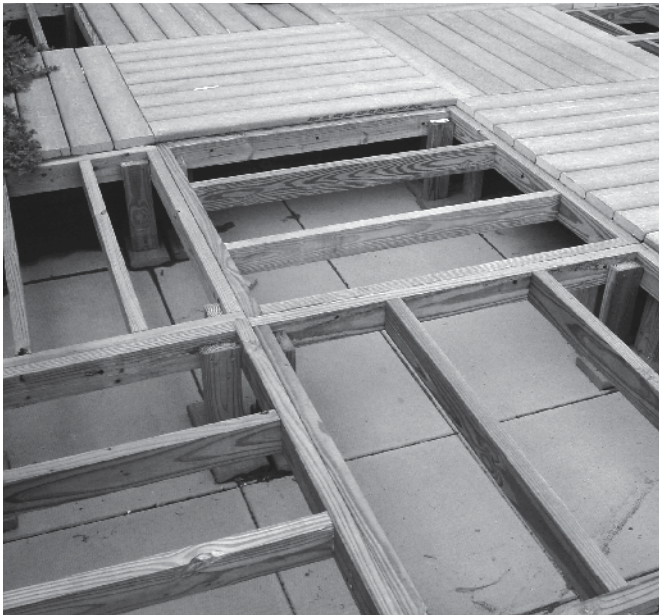

A sleeper system is a buffer between a solid surface and Trex® decking. Drainage, access, and airflow are critical. Water must be able to flow through and away from the deck. For repairs and removal of debris, joist system access is necessary. Good airflow will keep the decking dry and in good condition.

Trex, when used with a sleeper system, must be supported below its entire length and if used in a roofing application, the supports must run the direction of the pitch of the roof to facilitate proper drainage. In addition, sleeper joists must be attached to the roof structure in a manner that stabilizes the deck frame. Failure to do so may result in a poor structure which will compromise deck performance.

In areas of application where a sleeper system is required that would not be susceptible to excessive debris buildup (examples would include covered areas such as balconies, porches, etc.), a minimum height of 38 mm for pressure-treated joists as well as a minimum 6 mm gap between Trex decking would be acceptable. These areas would still have to be designed to allow for proper drainage and hidden fasteners would be acceptable. However, if access to the structure under the decking is required, it would be recommended to use either the Universal Fastener (plastic) or 51 mm composite decking screws. A 6 mm to 13 mm gap is still required when abutting walls or other fixed objects.

In all other areas where there could be excessive water buildup along with debris buildup, Trex would still recommend a minimum height of 89 mm for pressure-treated joists, as well as a gap of 10 mm. For this application, hidden fasteners would not be recommended and standard 76 mm composite screws would be used.

**ALWAYS** consult your local building code authority for proper details on roof and railing installation to the roof structure if required.

### ROOFTOP DECK TIPS

- » If you want to access the roof, you must build the Trex deck in removable sections or with removable fasteners.
- » You must attach the sleeper joists to the roof structure so that they stabilize the deck frame. Failure to do so may result in a poor structure which will compromise deck performance.



## CODE COMPLIANCE

### Joist Spanning for Decking

The joists must be spaced on center according to the chart below. Be sure that joists are level and plumb. Trex® decking must span at least three joists. For heavy items such as hot tubs, planters, etc., consult a local building engineer or inspector for span recommendations. If you want to minimize the appearance of joists through the spaces between boards, paint the top of your joists black.

For a Materials Safety Data Sheet (MSDS), please visit [trex.com](http://trex.com)

**ADJUST JOIST SPANNING TO ACCOMMODATE ANGLED DECKING PATTERNS\***

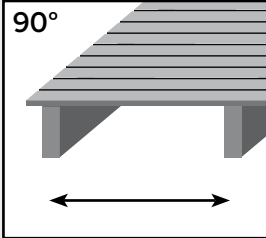

90°

Perpendicular to joists. See chart below.

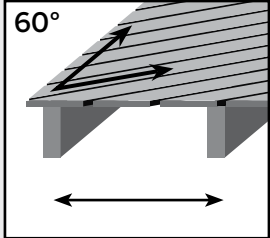

60°

At a 60° angle, maximum joist spanning is 51 mm less than listed in the chart below.

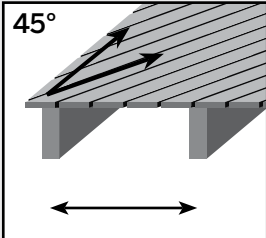

45°

At a 45° angle, maximum joist spanning is 102 mm less than listed in the chart below.

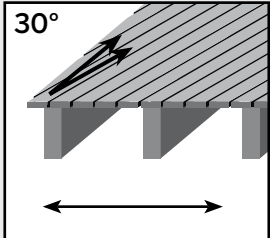

30°

At a 30° angle, maximum joist spanning is 1/2 of the distance listed in the chart below.

<b>TREX DECKING SPAN CHART (On Center)</b>			
	<b>Residential Decks, Light Duty Docks, Residential/Day care Playground</b>	<b>Commercial Decks, Boardwalks and Marinas</b>	
Decking Loading	4560 N/m <sup>2</sup>	4788 N/m <sup>2</sup>	9576 N/m <sup>2</sup>
140 mm x 25 mm Boards	450 mm	406 mm	305 mm

\*Only available in select areas.

## GAPPING

You must gap Trex® decking, both end-to-end and width-to-width. Gapping is necessary for drainage and the slight thermal expansion and contraction of Trex decking boards. Gapping also allows for the shrinkage of the wood joist system.

- » **ALWAYS** follow Trex-recommended gapping guidelines.
- » Maximum allowable perpendicular overhang for Trex is 102 mm.
- » All decks require air circulation to keep them dry and looking good. To improve air flow, leave openings under the decking or increase gapping to 10 mm.

WIDTH-TO-WIDTH GAP	
Above 4.5°C*	6 mm
Below 4.5°C*	10 mm

\*Temperature at installation.

END-TO-END/END-TO-WIDTH AND ABUTTING GAP		
	End-to-End/ End-to-Width	Abutting Gap
Above 4.5 C*	3 mm	6 mm
Below 4.5 C*	5 mm	13 mm

\*Temperature at installation.

- » When you use the recommended hidden fasteners, the placement of the hidden fastener establishes the designated gap size.

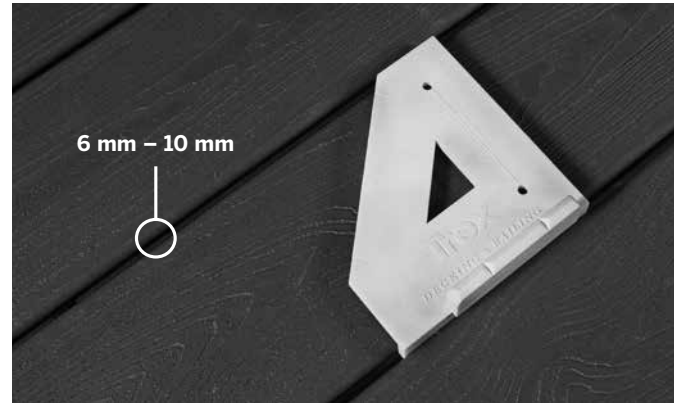

### Width-to-Width

The minimum required width-to-width gapping is 6 mm. When installing in temperatures below 4.5°C, Trex recommends 10 mm gapping. For docks and heavily wooded areas, Trex recommends a 10 mm gap as well. No gapping should ever exceed 13 mm.

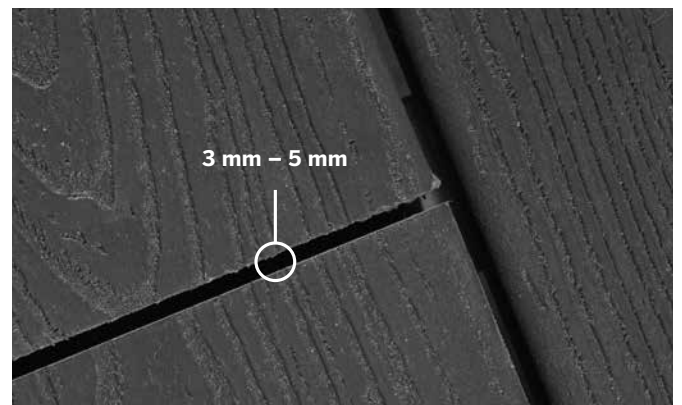

### End-to-End/End-to-Width

Gap Trex decking end-to-end, based upon the temperature at installation. See chart at left.

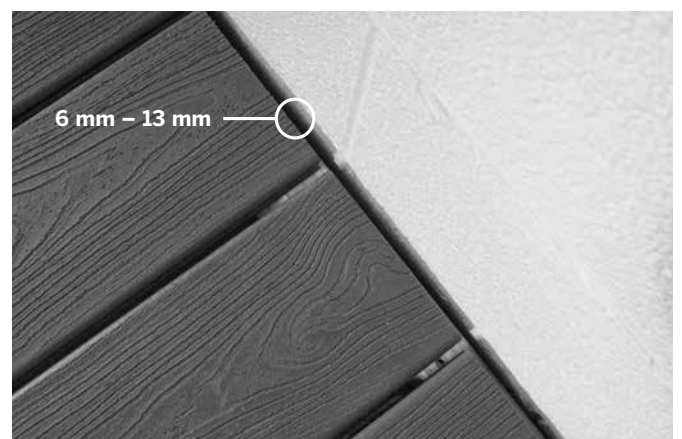

### Abutting Solid Objects

When decking is abutting a wall, you must also gap it 6 - 13 mm depending on the temperature at installation. See chart at left.

# STAIRS

## Stairway Detail

- » Fasten stair treads continuously across at least four stringers.
- » See chart (at right) for center-to-center spacing of profiles.
- » Dress the sides of the stringers and risers with Trex® Fascia or trim for a finished look.
- » Gapping between Trex boards on stair treads must be 6 mm - 10 mm.
- » The overhang of the stair tread is not to exceed 13 mm.

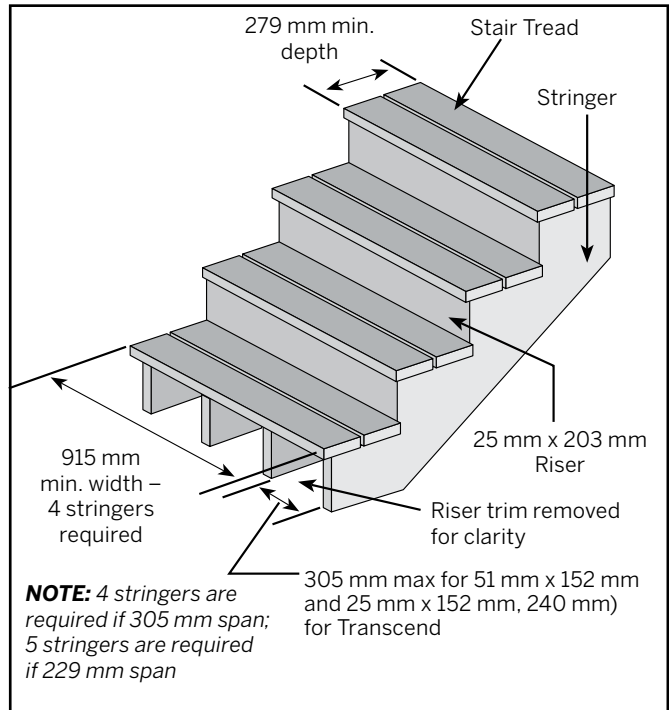

MAXIMUM SPACING ON CENTER OF JOIST	
51 x 152 mm, 25 x 152 mm Boards	305 mm

## HOW TO INSTALL STAIR TREADS

### Installation Options

#### Option 1: Using Hidden Fastening System

1. Install start clips against riser on each step.
2. Install first board.
3. Install second board.
4. Secure with screws from top of second board into stringer boards.

#### Option 2: Using 51 mm x 102 mm Wood Support Blocks

1. Install start clips against riser on each stair tread.
2. Install first board.
3. Attach 51 mm x 102 mm long wood support blocks between stringers.
4. Pre-drill holes up through blocks.
5. Install second board.
6. Secure with screws from bottom through blocks and into stair treads.

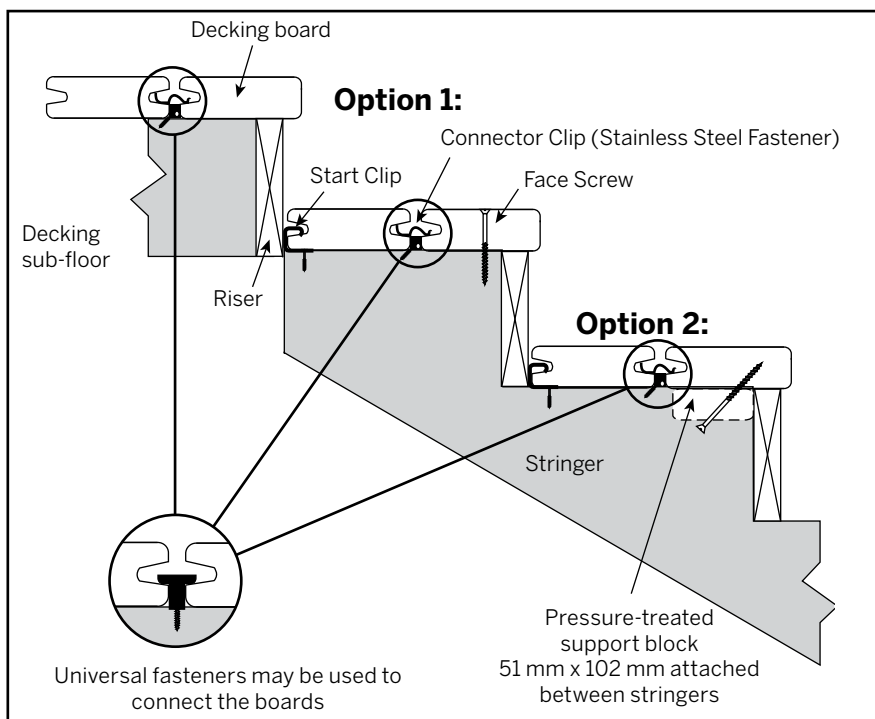



# HOW TO INSTALL UNIVERSAL HIDDEN FASTENERS

## PARTS

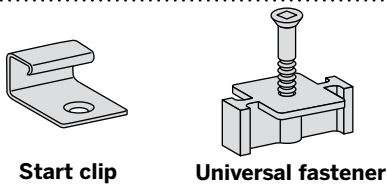

Start clip

Universal fastener

## TOOLS NEEDED

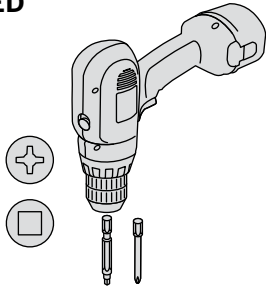

**NOTE:** Maximum spacing of deck boards using Hideaway system is 450 mm on center. Fasteners provide 6 mm gap when installed correctly.

## Installing Start Clips and First Board

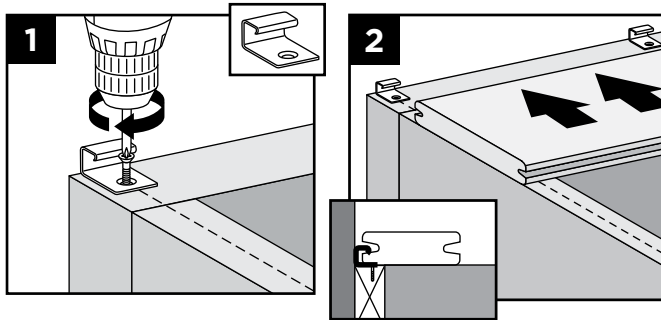

1. Install start clips on edge of ledger board, centered on each joist. Secure clips with screws.
2. Push grooved edge of deck board into start clips.  
**Important:** First board MUST be straight and well secured.

## Install Universal Fasteners

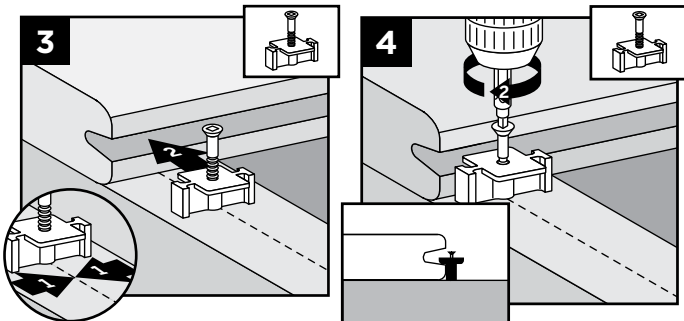

3. Insert fastener into grooved edge of deck board.
4. Align screw hole in fastener with center of joist. Continue along the length of the board at every joist.

**NOTE:** Screw only half way down. **DO NOT** fully tighten.

## Installing Second Board

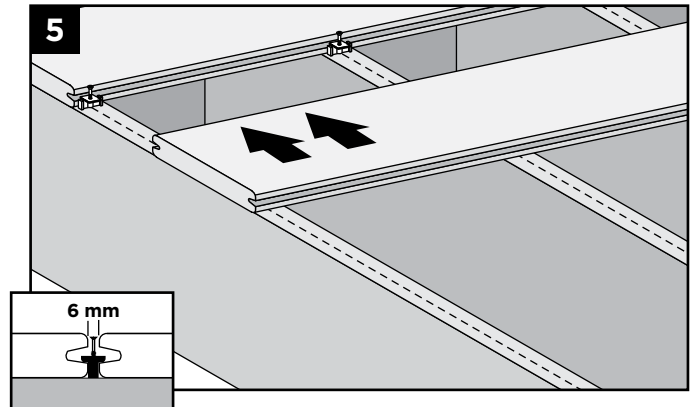

5. Slide second board into place, making sure fasteners fit into groove. Install the next universal fastener on the other side of the second board in the same manner as Steps 3 and 4. **DO NOT** fully tighten the screw.

## Complete Installation

6. Tighten screws on fasteners in first row. Proceed with Steps 3 through 5, tightening down each row after board that follows is in place. Be sure to use a long #1 square bit.

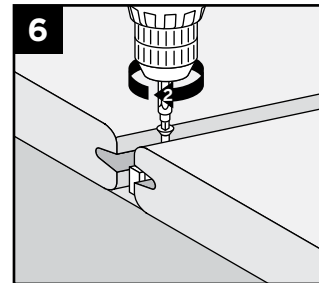

## Installing Last Board

### Option 1:

#### Using Fascia Board

- 7a. Pre-drill pilot hole at an angle through grooved edge of deck board into ledger board. Install 64 mm screws through pilot holes to secure. Attach a fascia board flush with deck surface.

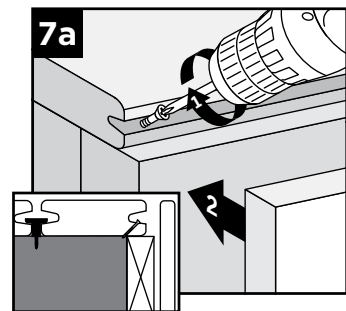

### Option 2: With Deck Board Overhang

- 7b. Pre-drill pilot holes at 45° angle from below deck surface through rim joist. Seat last board into fasteners overhanging rim joist. Secure board with 64 mm screws using pilot holes. Position fascia board below overhanging deck board.

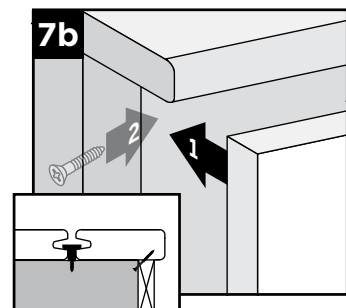

# TIPS FOR INSTALLING A TREX HIDEAWAY® HIDDEN FASTENING SYSTEM

## Installing Angled Deck Boards in Corners

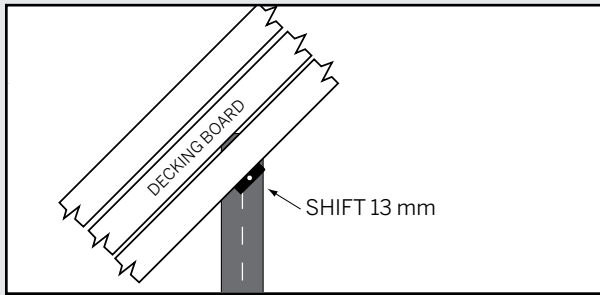

**ALWAYS start in corner** with a small triangular piece of decking at 45° and work outwards. Install Trex Hideaway fasteners 13 mm off center to keep fastener screws in middle of joists.

## How to Butt Seams

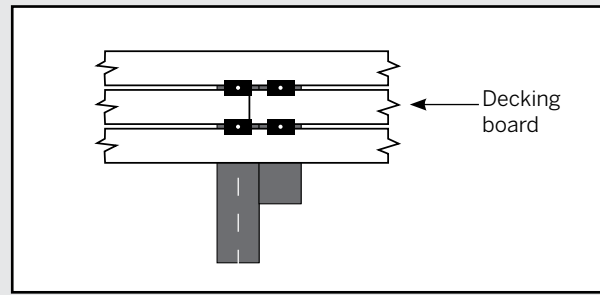

1. Install 254 mm - 305 mm framing boards along joists where seams will butt.
2. Place additional fasteners on the adjacent board over the joist and framing boards where the seam will be.
3. Put the first board of the seam in place and secure with fastener.
4. Butt end of second board to first and secure with fastener.
5. Place second set of fasteners on each side of butt seam for next board.

## HOW TO REPLACE TREX® BOARDS INSTALLED WITH UNIVERSAL FASTENERS

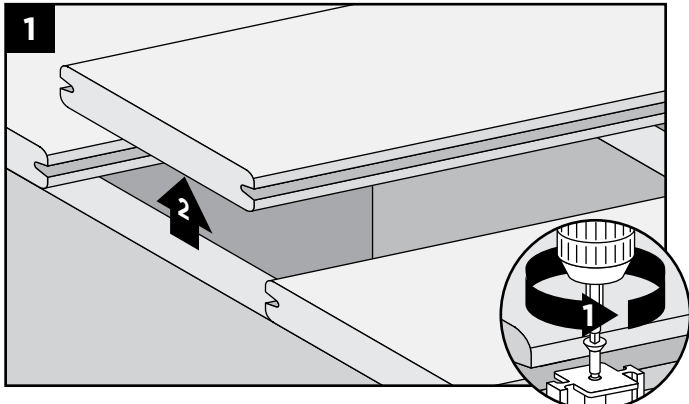

1. Remove screws from fasteners on both sides of board to be replaced and remove board.

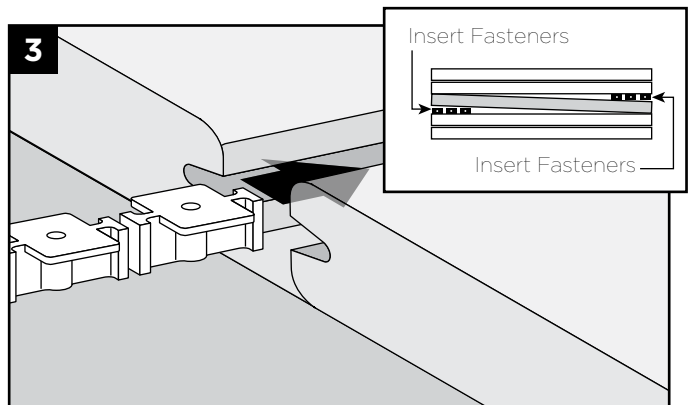

3. Slide a fastener for each joist into board grooves from both ends of the board.

**NOTE:** You may have to loosen adjacent boards to slide fasteners into position.

4. Position replacement board and secure fasteners on center of each joist.

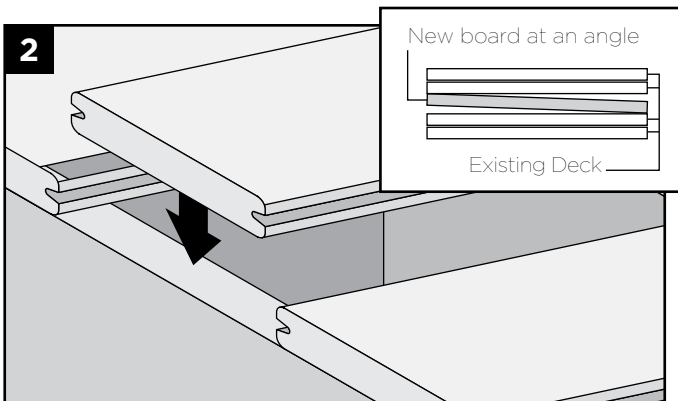

2. Angle new board to place. See inset box (above).